

# Renault

Karty ratownicze dla służb ratowniczych

Karty te zostały stworzone wyłącznie w celu technicznego ratowania osób z pojazdów. Zawarte informacje przeznaczone są dla przeszkolonego personelu ratowniczego.



# KANGOO Z.E.

TYP: FW, 2011-

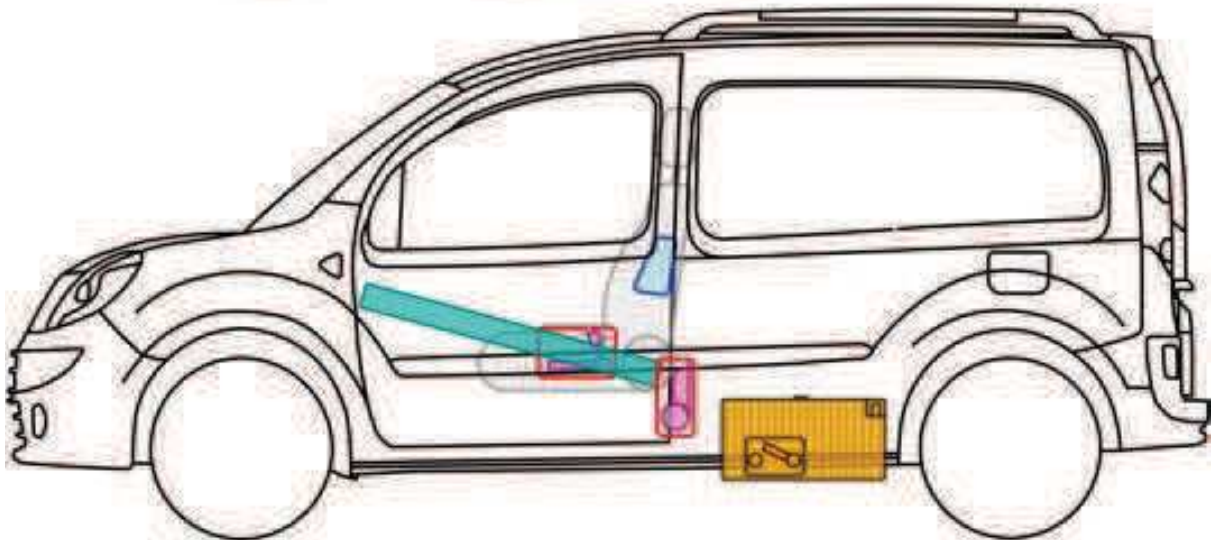
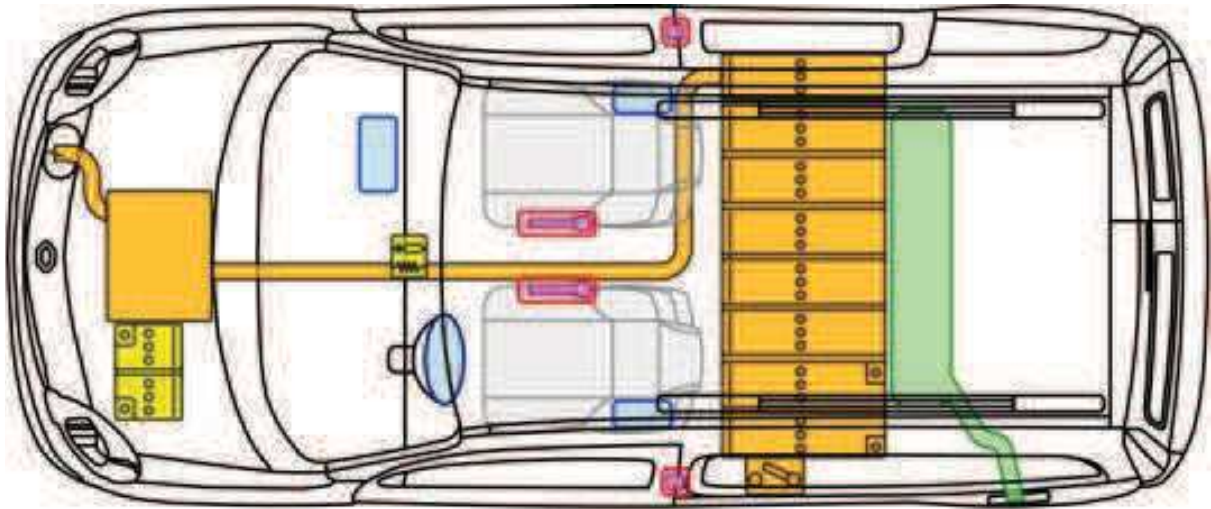

## Legende

	Airbag		Karosserie- verstärkung		Steuergerät		Hochvolt- batterie
	Gas- generator		Überroll- schutz		12 V Batterie		Hochvolt- leitung/ -komponente
	Gurt- straffer		Gasdruck- dämpfer		Kraftstoff- tank		HV- Trennstelle



# KANGOO MAXI Z.E.

TYP: FW, 2011-

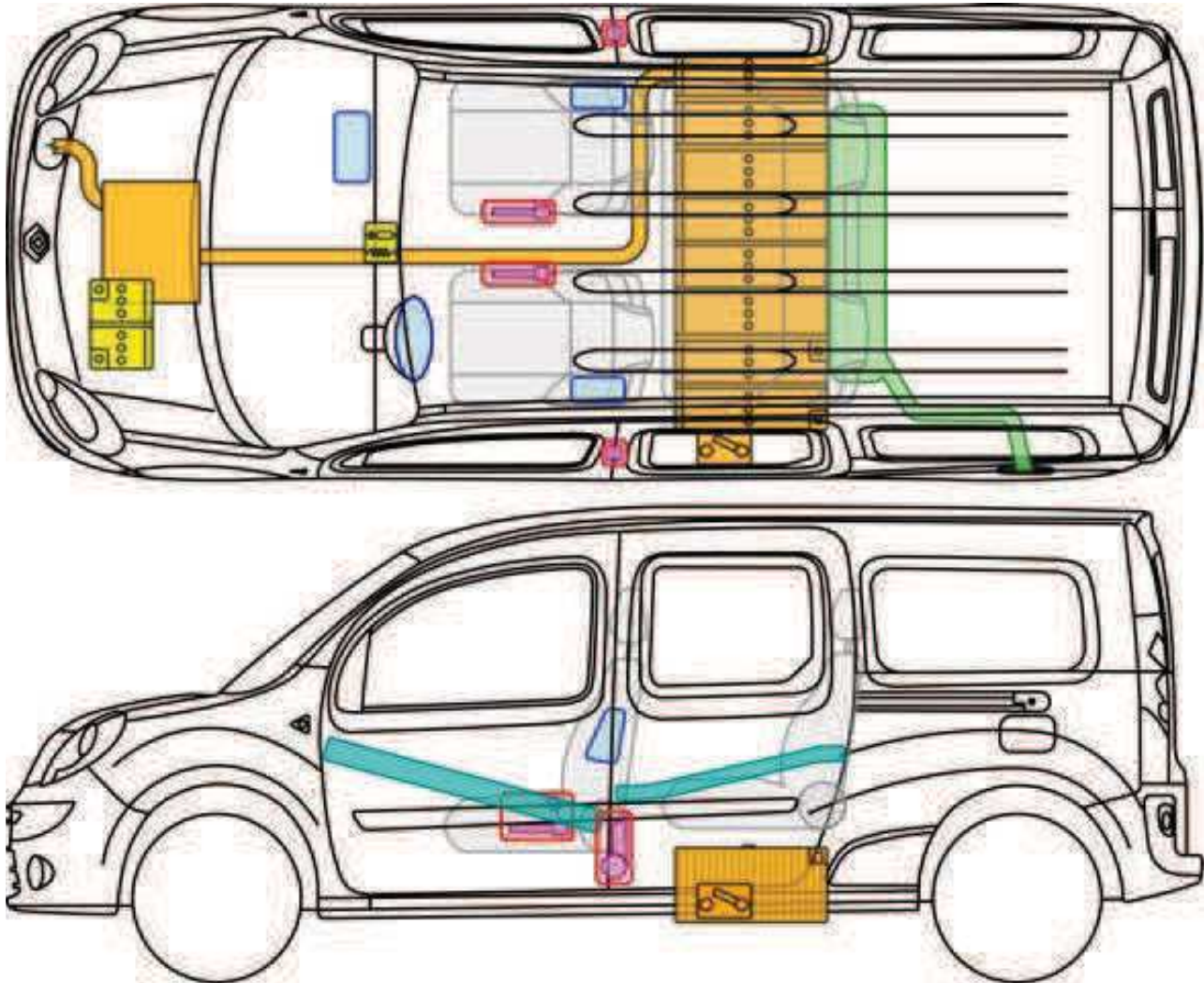

## Legende

	Airbag		Karosserie- verstärkung		Steuergerät		Hochvolt- batterie
	Gas- generator		Überroll- schutz		12 V Batterie		Hochvolt- leitung/ -komponente
	Gurt- straffer		Gasdruck- dämpfer		Kraftstoff- tank		HV- Trennstelle



# KANGOO ZE H2

Geprüft und genehmigt durch:



MINISTÈRE DE L'INTÉRIEUR

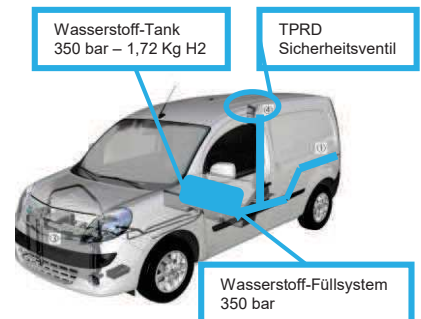
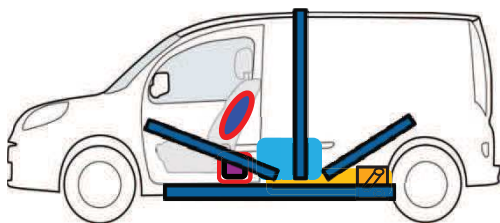
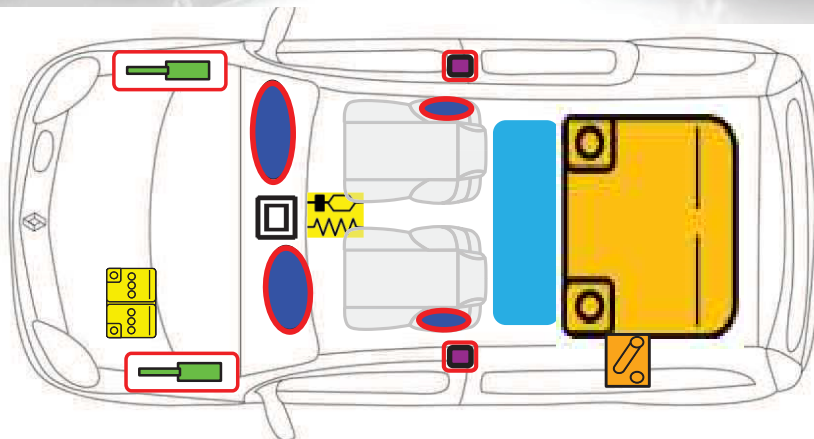

	Airbag		Gasgenerator		Gurtstraffer		SRS-Steuergerät		Überrollschutz
	Aktiver Fußgänger-schutz		Gasdruck-dämpfer		Karosserie-verstärkung		Sensibler Bereich		Wasserstoff-Tank
	12 V-Batterie		Ultrakondensator Niederspannung		Kraftstofftank		Gas-Tank		Sicherheits-ventil
	Hochvolt-Batterie		Hochvolt-leitung/-bauteil		HV-Trennstelle		Hochvolt-Sicherungen		Hochvolt-Ultrakondensator

Marke	Modell	Phase	Einführungsjahr	Interne Bezeichnung	Erstellungsdatum	Aktualisierung	Version
Renault	Kangoo ZE H2	1	2015	RSE-FAD-Kangoo ZE H2 -2015-v1	01/09/2015		1

## Identifizierung

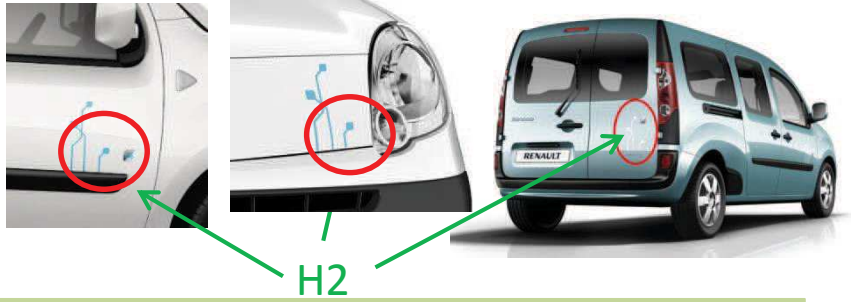

EV

H2

## Arretieren / Stabilisieren / Anheben

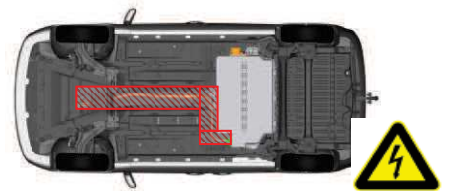
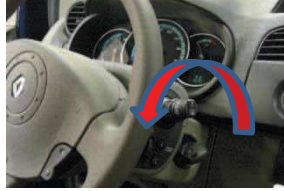

## Vermeidung direkter Gefahren / Sicherheitsbestimmungen / PSA

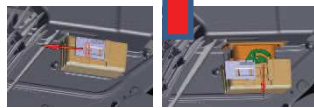
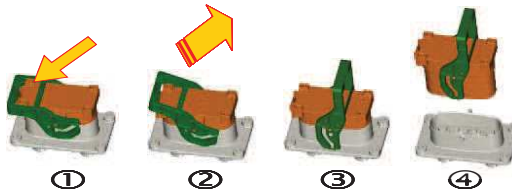

 Hochvolt-Trennstelle:  
Service-Plug

## Gefahren im Brandfall / Sicherheitsbestimmungen / PSA

Li-ion

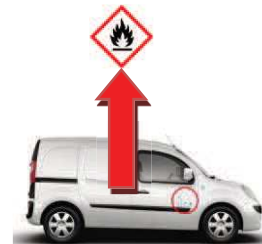

H2



## Gefahren / Flüssigkeiten / Gase / Feststoffe / PSA

Li-ion



H2



## Symbole

PSA

Löschen mit Wasser

Wärmebild-Kamera

Entzündbar

Explosiv

Ätzend

Umwelt-schädlich

Nicht zerbrechen oder öffnen!



Marke	Modell	Phase	Einführungsjahr	Interne Bezeichnung	Erstellungsdatum	Aktualisierung	Version
Renault	Kangoo ZE H2	1	2015	RSE-FAD-Kangoo ZE H2 -2015-v1	01/09/2015		1



# ZOE Z.E.

TYP: AG, 2013-

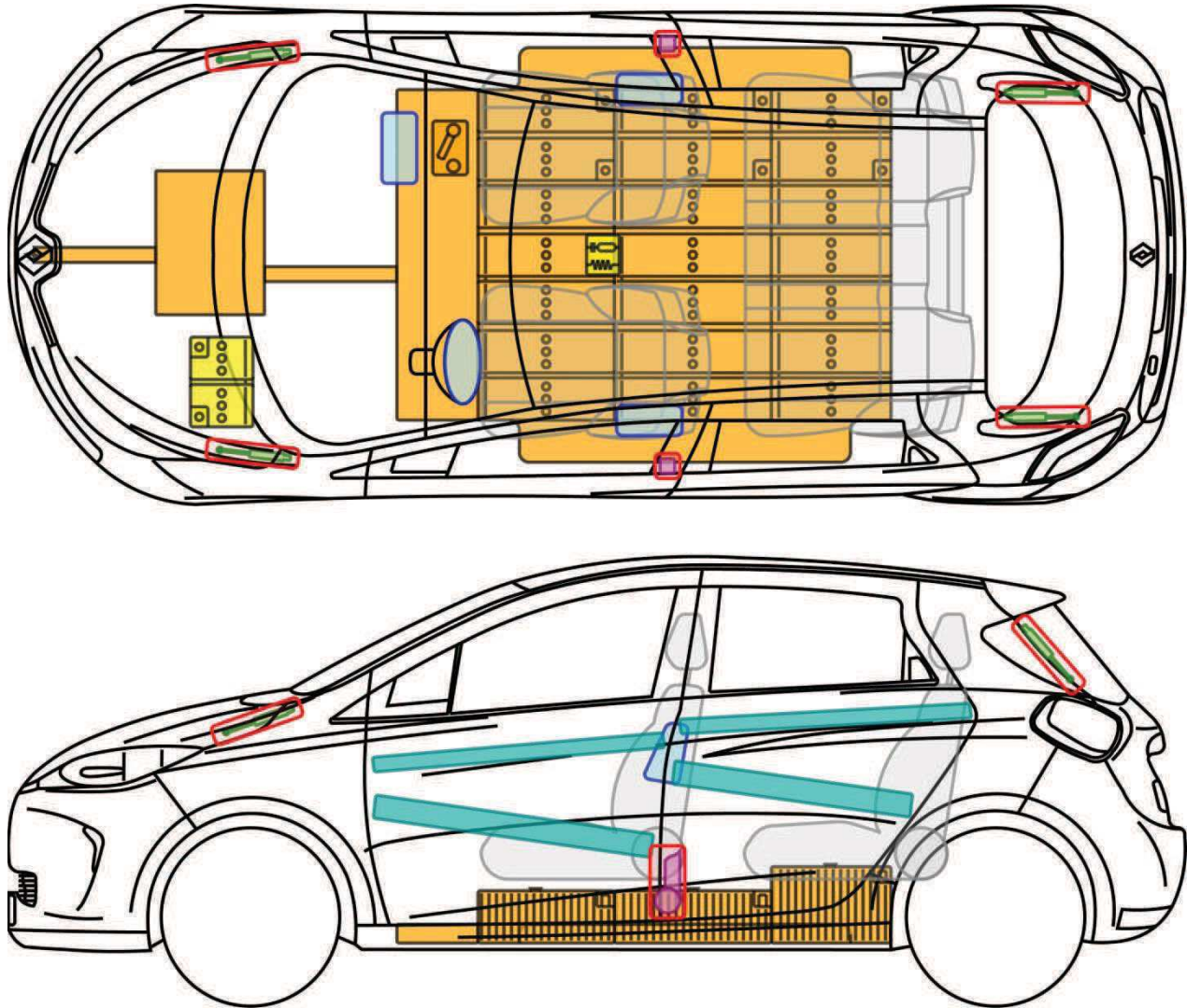

## Legende

	Airbag		Karosserie- verstärkung		Steuergerät		Hochvolt- batterie
	Gas- generator		Überroll- schutz		12 V Batterie		Hochvolt- leitung/ -komponente
	Gurt- straffer		Gasdruck- dämpfer		Kraftstoff- tank		HV- Trennstelle



# FLUENCE Z.E.

TYP: LZ, 2011-

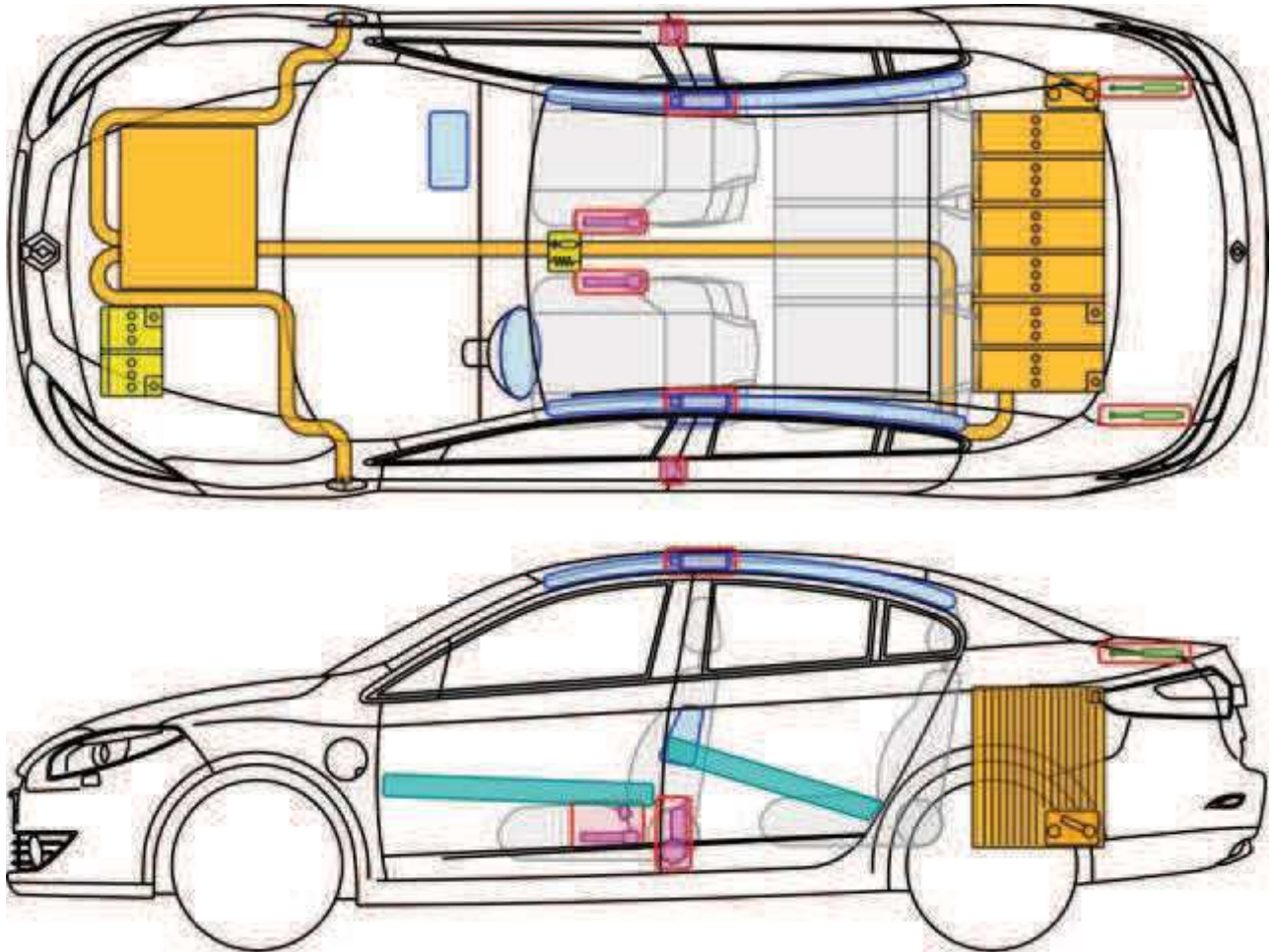

## Legende

	Airbag		Karosserie- verstärkung		Steuergerät		Hochvolt- batterie
	Gas- generator		Überroll- schutz		12 V Batterie		Hochvolt- leitung/ -komponente
	Gurt- straffer		Gasdruck- dämpfer		Kraftstoff- tank		HV- Trennstelle



# TWIZY

TYP: AC, 2012-

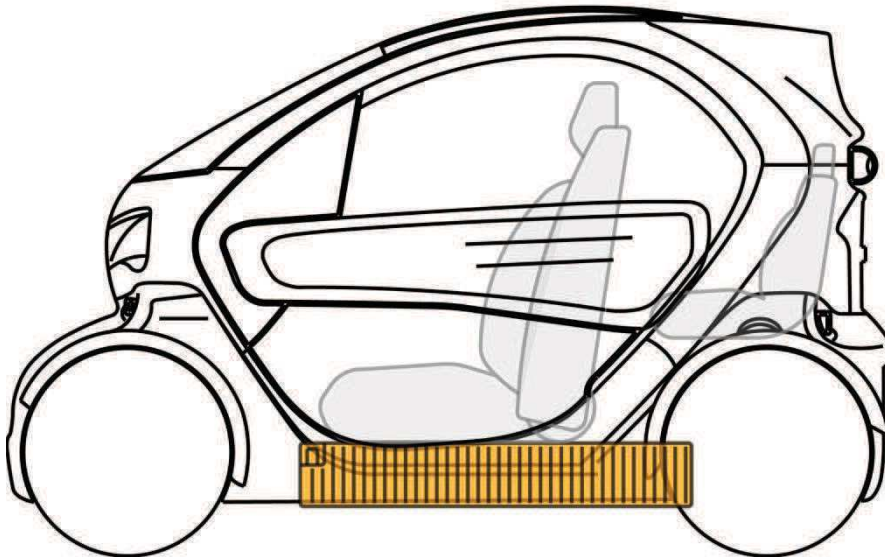
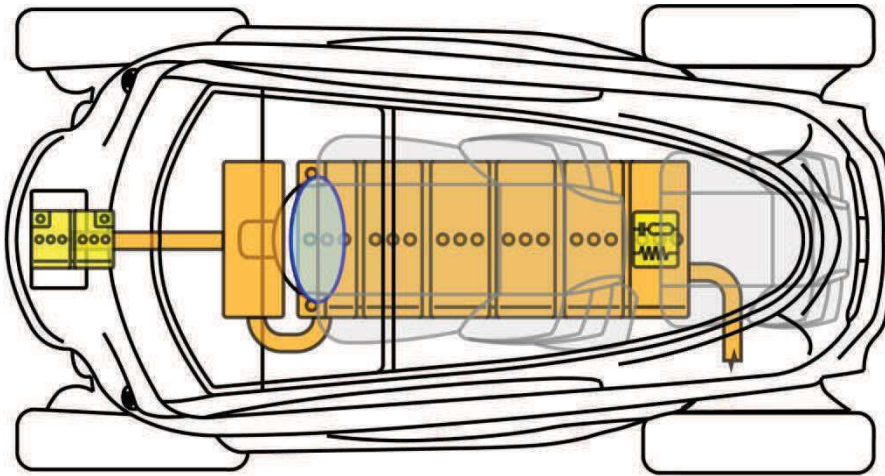

## Legende

	Airbag		Karosserie-verstärkung		Steuergerät		Hochvolt-batterie
	Gas-generator		Überroll-schutz		12 V Batterie		Hochvolt-leitung/-komponente
	Gurt-straffer		Gasdruck-dämpfer		Kraftstoff-tank		HV-Trennstelle